



INTEGRAL

SCALE MODEL
CONSTRUCTION MANUAL



Thorsten.Siwitza@esa.int

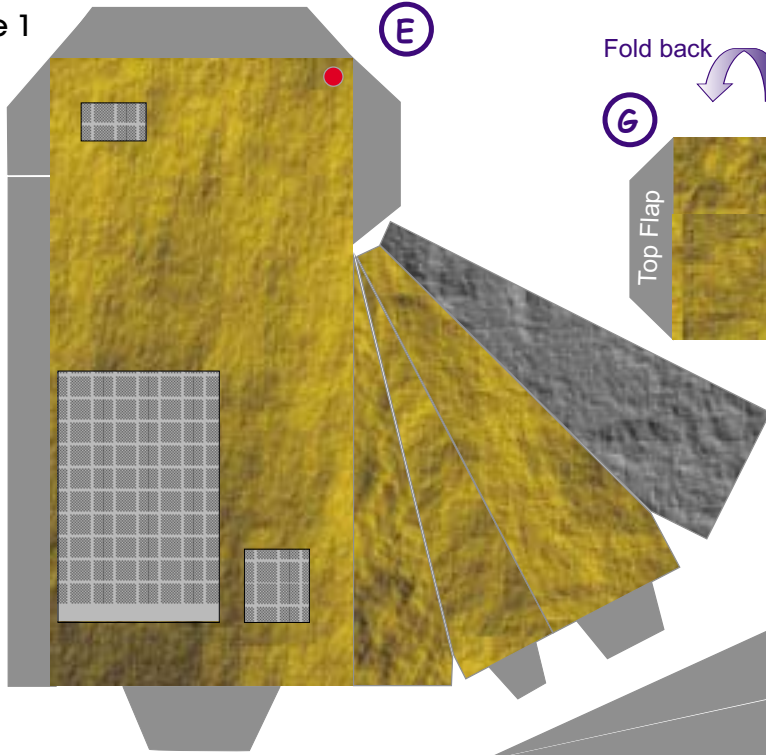

Fold back

G

Top Flap



Fold back

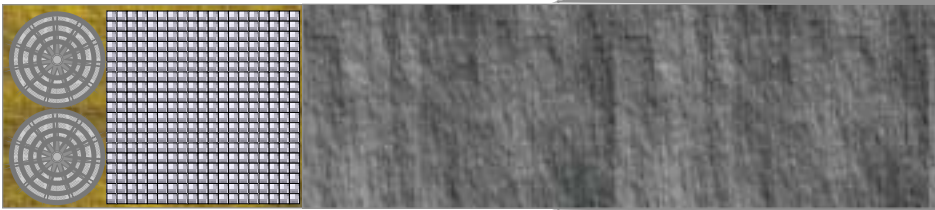

F

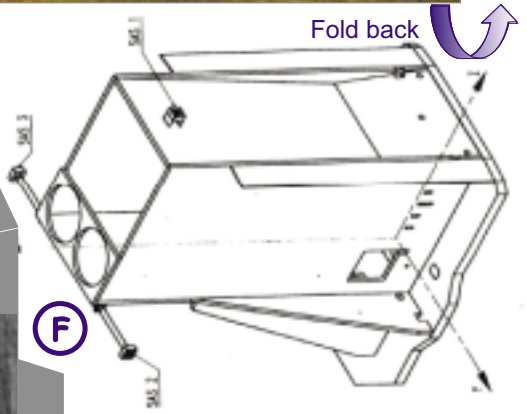

E

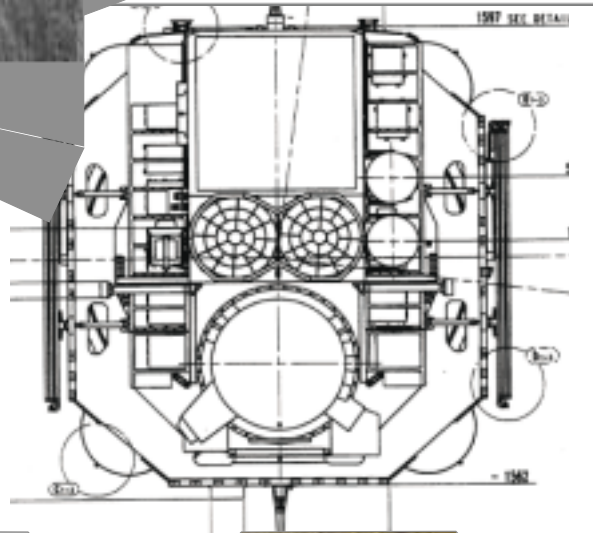

I

Underside



J

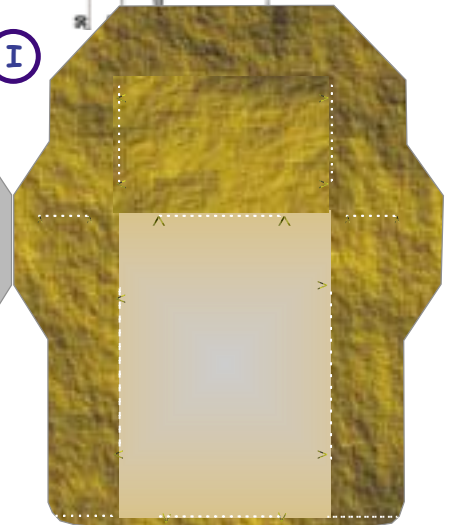

H

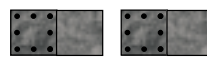

Backside of Flap: black

K

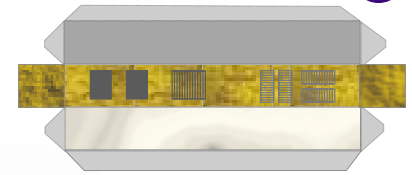
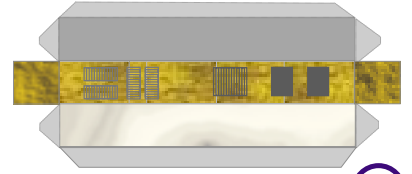
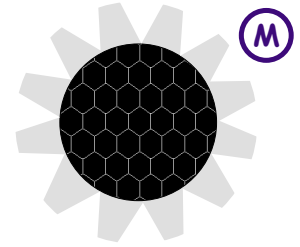
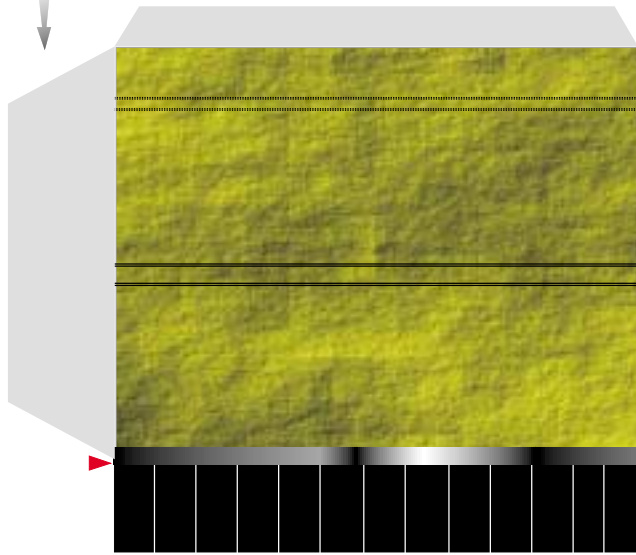
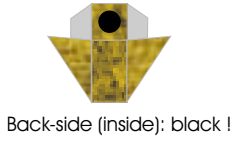

L

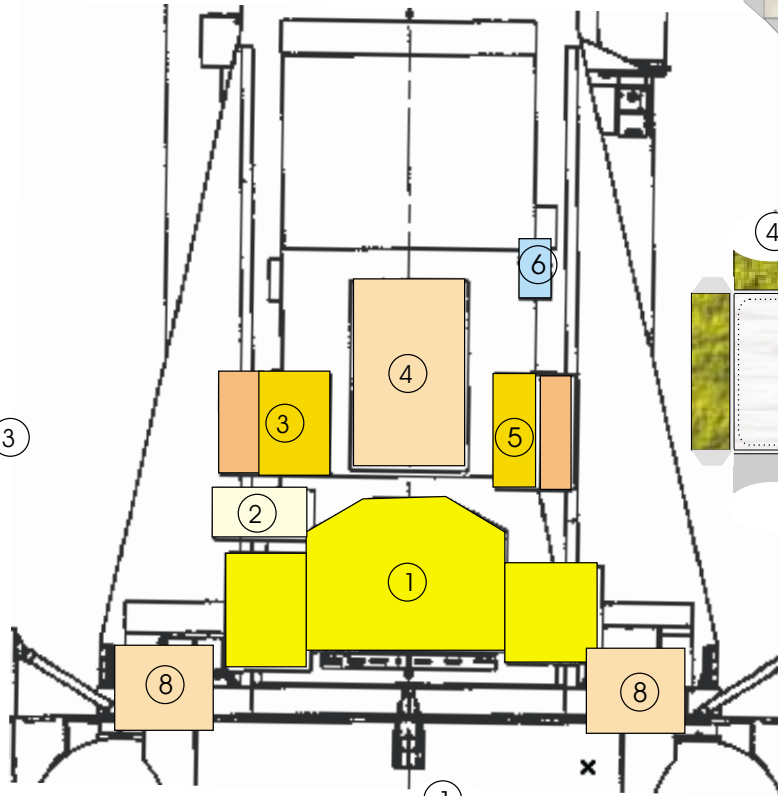

6

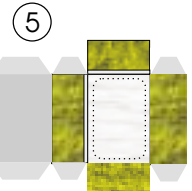
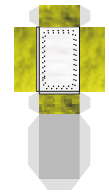
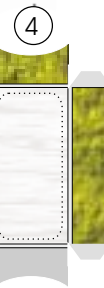

3

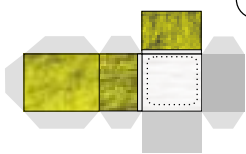

2

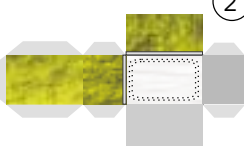

1

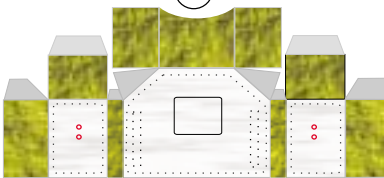

N

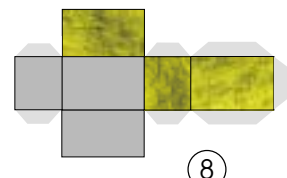
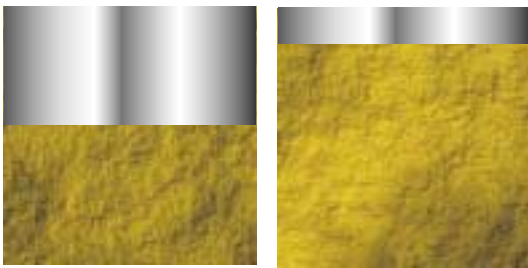

8

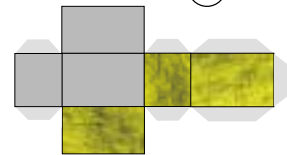

O

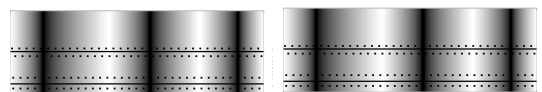
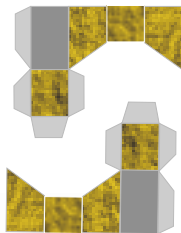

P

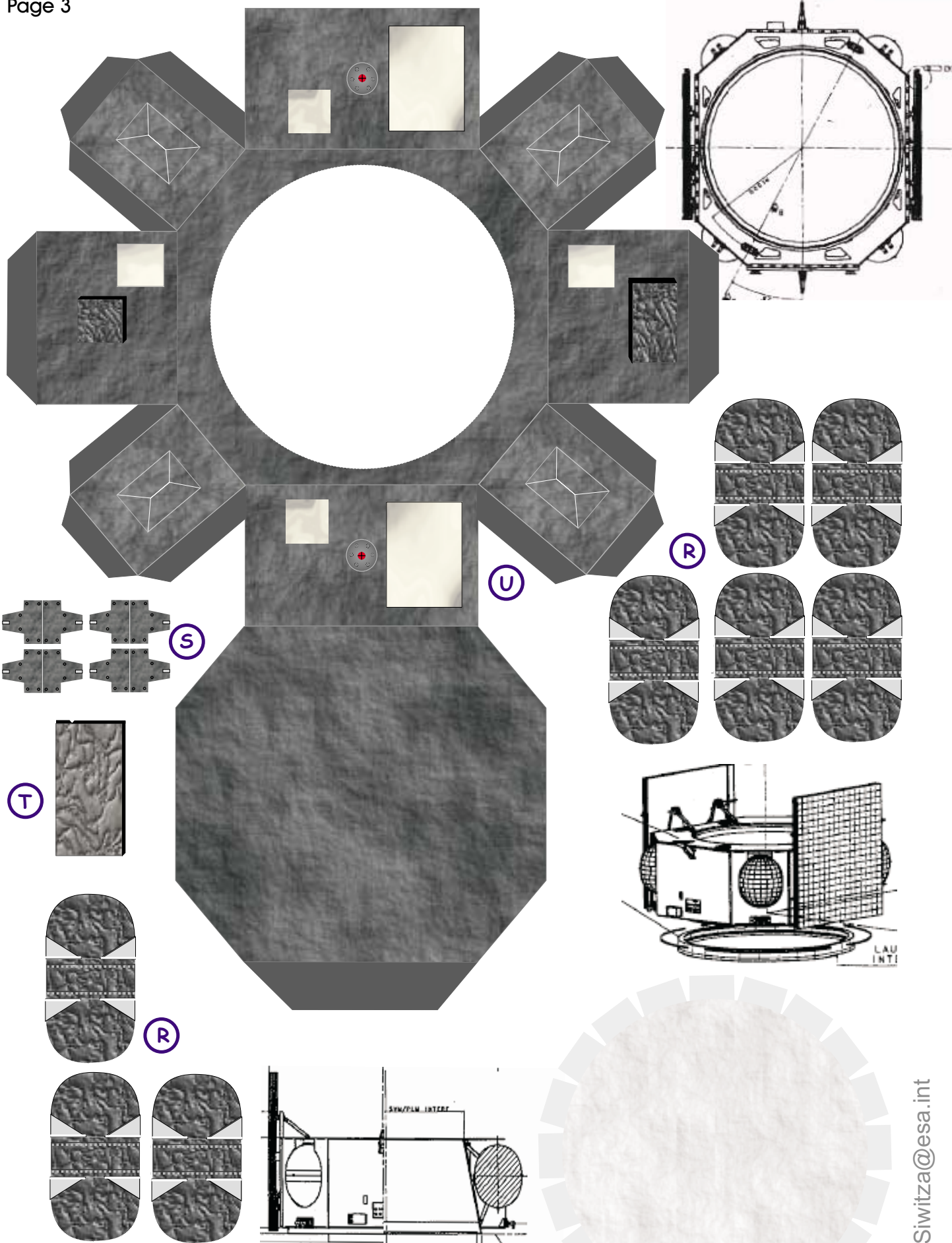

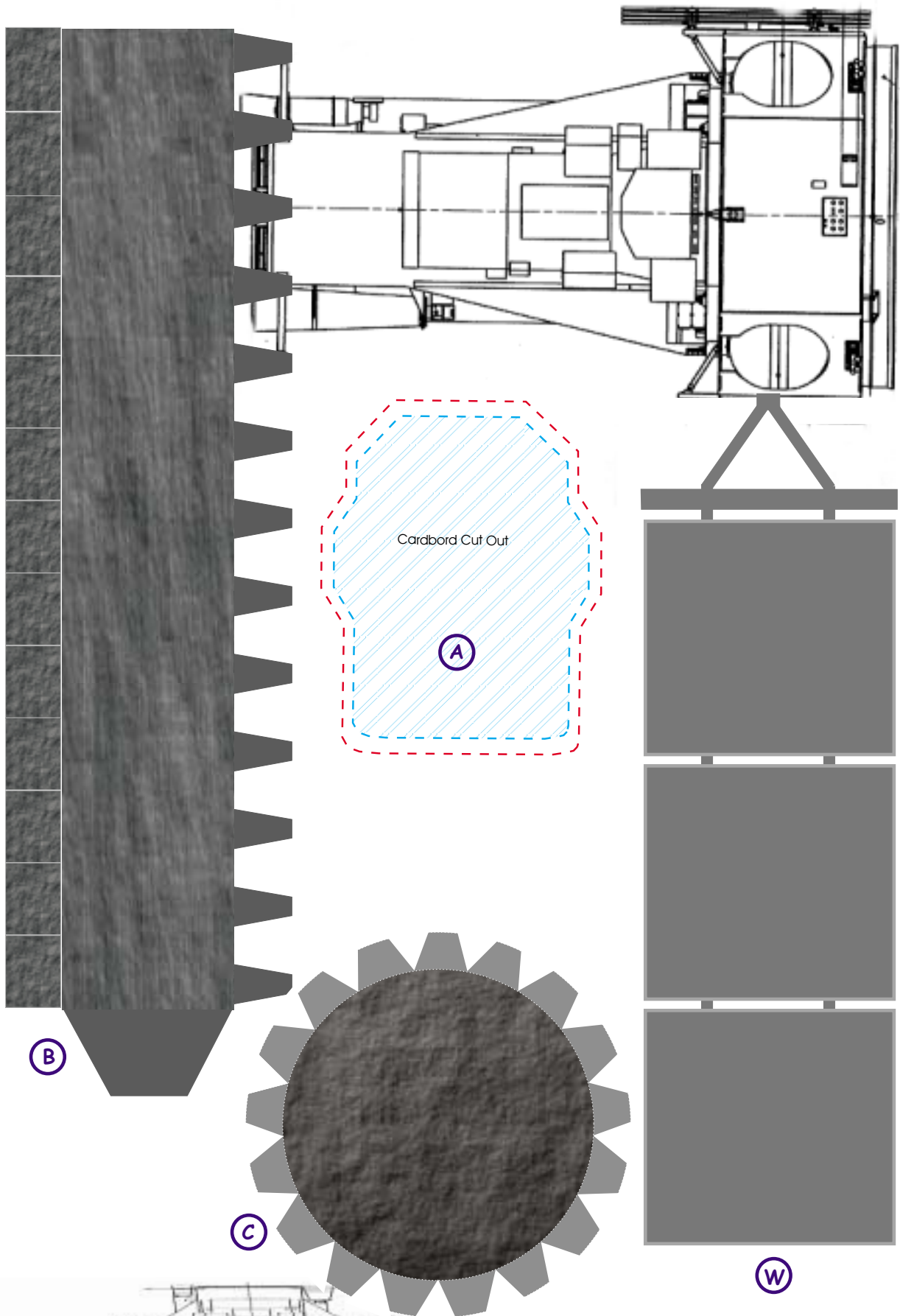

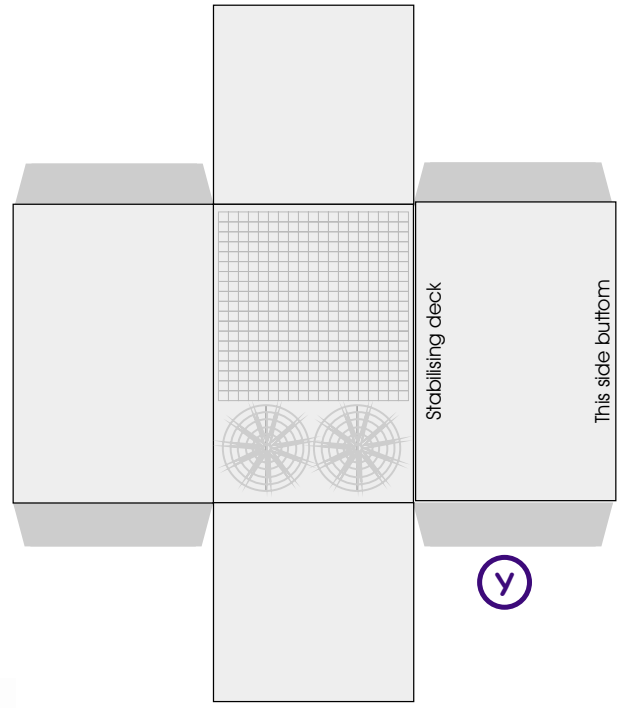
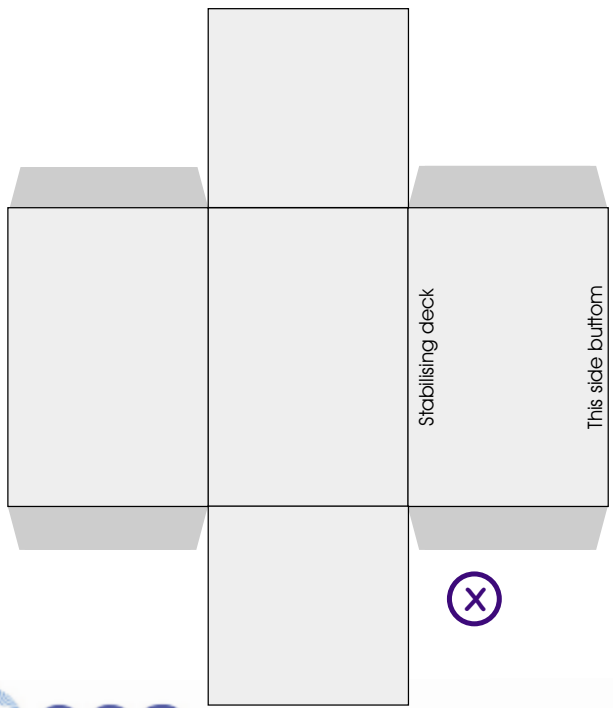
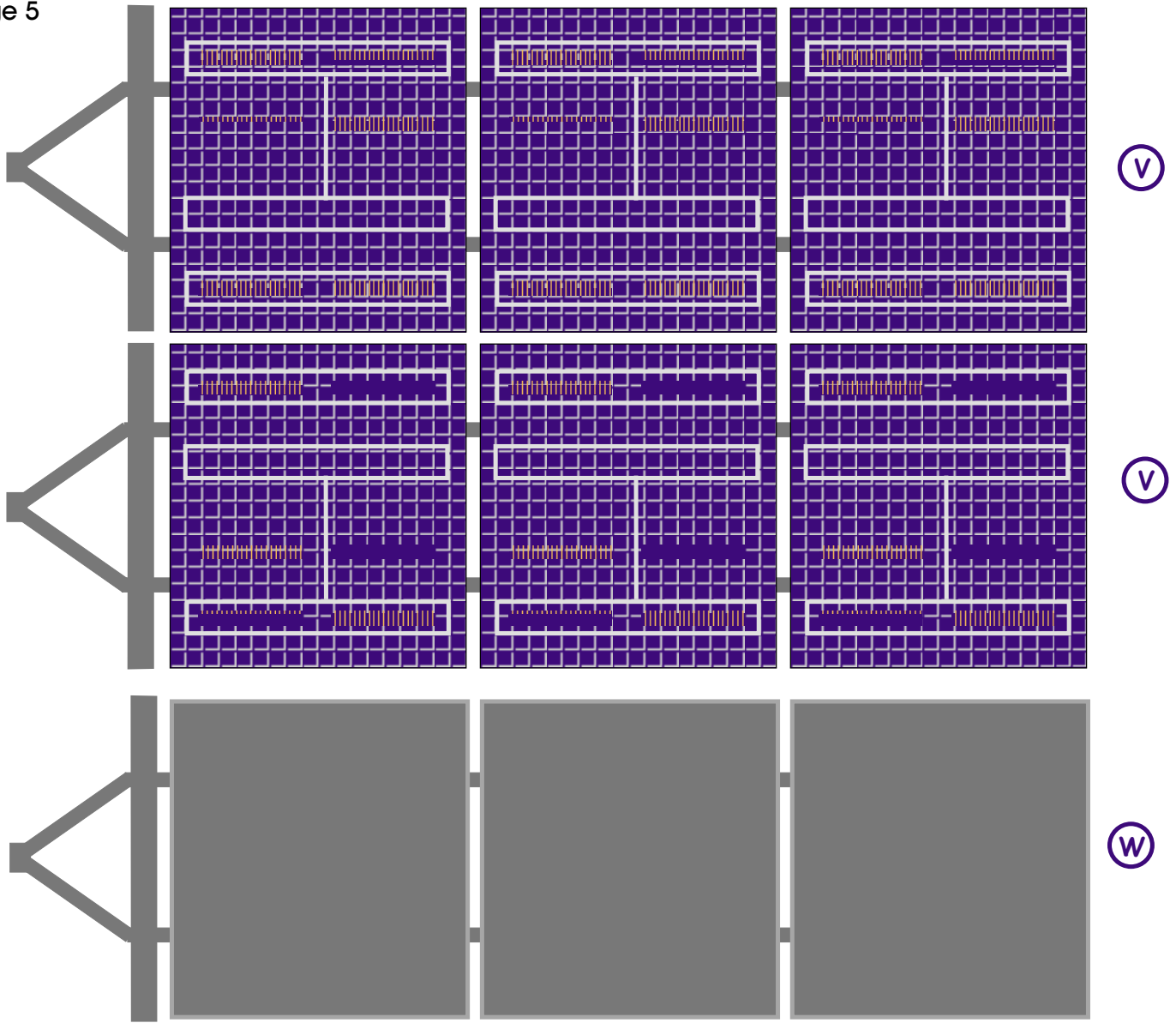

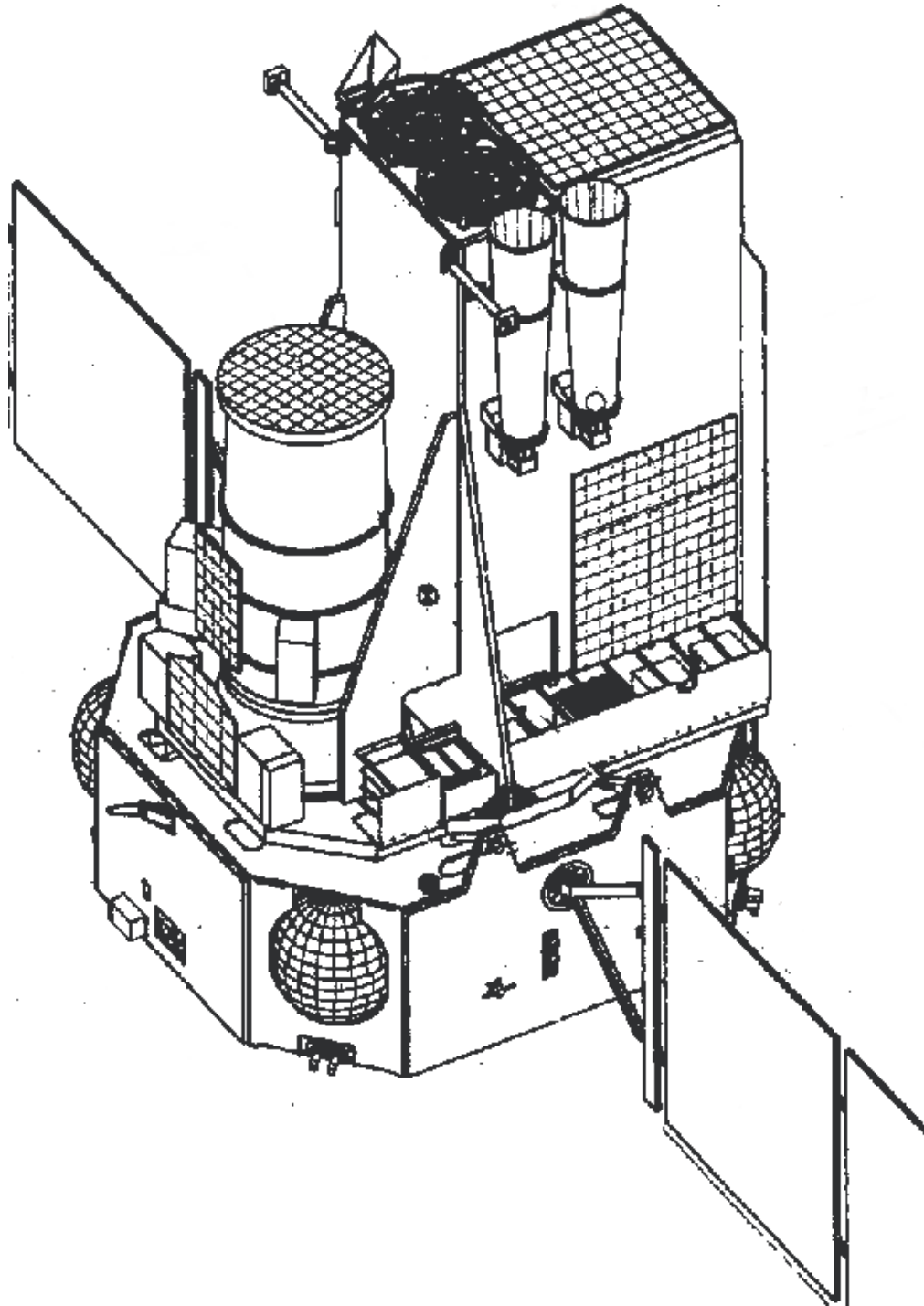

SCALE MODEL

Construction Manual

This is the instruction manual for the scale model of the *ESA Integral* spacecraft. It is a step-by-step manual and it will probably take you a good evening to complete it. Words in *Italic* are names of actual spacecraft units and instruments. These are listed in alphabetic order in the appendix to this manual together with an explanation of their function.

But let's get started. What is needed?

- Cardboard
- Glue
- Scissors, small and standard
- Ruler
- Knife
- Needles
- Toothpicks
- Barbecue sticks
- Aluminium Foil
- Thread

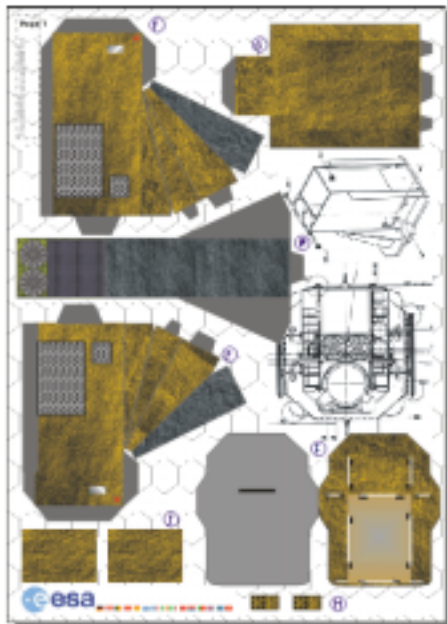

Take the first sheet (page 1) with the symmetrical dark golden shapes - they will become part of the structure of the *Payload Module (PLM)*. You find letters in blue circles for reference next to each element that needs to be cut out.

The elements (E) make the side panels of the *IBIS* structure; (F) the front and top, while (G) becomes the back panel. It is grey, and if you look carefully you can count the six surfaces, the so-called panels of the spacecraft. On page 6 you find a three-dimensional drawing of the spacecraft. Refer to the drawing from time to time to relate the different elements of the spacecraft to each other.

When you have cut out the shapes of the structure, take a ruler and a knife and

prepare the folding edges as follows: lay the ruler along an edge and run the blunt edge of the knife along it, but do not cut. This makes folding easier. Now fold against the edge of the ruler to get a nice sharp crease. The grey attachments on each element will be folded and eventually covered with glue. Grey shapes that have an internal structure are coated surfaces of the spacecraft and not to be confused with the folding strips. Where folding is to be done is generally obvious, and the manual will guide you through the few tricky bits of this specific model all right.

On the side panels of the *Payload Module (PLM)* find the small red dots. Pierce them all with a needle and then with a toothpick. Roll the sticks between your fingertips while making the holes ever larger to avoid tearing the edges. The holes will carry the *Sun Acquisition Sensor (SAS)*, which will be mounted with barbecue sticks to the *PLM* body.

Prepare all side panels for folding with the knife. The back panel (G) has two long folding edges running vertical through the dark golden fields. Fold these two and the top flap to the back. Do not fold the three bottom flaps.

Take the front panel (F) and fold the outer triangular flaps to the back, so that on both sides the white backsides of the flaps face each other. Then fold along the remaining line between the triangular (double thick) flap and the structured body. But this time fold it to the front. Again, do not fold the bottom flap. After folding the top panel, the front and back panel (G+F) should like this.



Take one of the side panels and start folding the triangular shapes. Start with the folding line running along the main rectangular side panel and the most inner triangular golden panel. Fold the triangular panel over the rectangular one, so the two golden sides face each other. The white backsides are facing you now. Fold the next triangular panels in alternating directions. In the end the grey part with the two circles of the *JEM-X* coded masks should be on top.

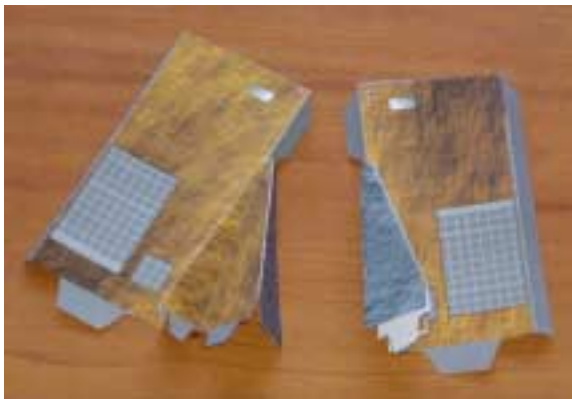

Glue the back panel's triangular flaps together. Do the same thing with the golden pair of true triangles on the side panels.

The long flaps on the sidewalls have a small white line on the upper part. Cut the flap there and bent the smaller upper part to the back and the longer lower one to the front. This front bent part is to be inserted in the flaps of the back panel. Thus apply glue to both sides of the front bent flap

and insert it into the corresponding bent flaps of the back panel. At the same time apply glue to the small upper flap of the side panel that was bent to the back. Glue it to the upper part of the back panel. Do the same things with the other sidewall. On page 5 you find two stabilising platforms. Cut them out, prepare the flaps and glue the platforms between the side panels of the *PLM*.



After mounting the two stabilizing platforms precisely onto the combined side & back panel, mount the second side panel. The dark back panel has to be mounted on the boxes of the platforms. Pay attention to the side flaps position. The triangular grey stabilisers of the back panel are to be enveloped by the golden double triangles of the side panels and firmly glued in. The top panel is to be connected to and glued on

the three side flaps of the side and back panel.

Now to the bottom of the *PLM*: Cut out the symmetrical and connected two parts (I). If you fold them over each other along the connecting line, you have the grey underside and the golden upper side. On this you find white dotted lines. They correspond to the grey flaps on the underside of the *PLM*. Take a sharp knife and cut along the lines. On one side the white lines are very close to the edge. Cut with the scissor from the side. Then try to sink all flaps of the *PLM* into the new slits of the golden underside. Fold and glue the flaps tight, then glue the underside on top to cover the folded flaps.



Turn the *PLM* over and find the two red dots that you have pierced earlier. On the bottom of the page you find two black rectangular shapes (J), representing the *Sun Acquisition Sensors*. Cut them out and roll them each over a toothpick to get two 1.5 cm long tight rolls. Apply some glue to fix the rolls, but do not glue them on the toothpick. Take one toothpick and stick them through the side panels. If necessary, shorten the toothpick that on both sides not more than 1.5 cm are visible outside the *PLM* body. Over these pieces you stick the little rolls and fix them with a drop of glue.



Lets leave the PLM and turn to page 3 with the structure of the SVM. First you cut out and prepare the large part, the body of the SVM, for folding. Work very accurately, since the folding lines will determine the correct angles and shapes of this major spacecraft part. Cut out the large white circle and pierce the red dots with needle, toothpick and barbeque-stick. On the four smaller side panels you find grey outlines of a rectangle with white lines inside. Cut only along these white lines with small sharp scissors. Prepare the grey lines with the

knife for folding, since they become four small flaps. On page 4 the element (C) can be glued on the underside of the octagonal piece of the main body (U).

The elements (R) are the tanks that protrude the SVM. The tanks are a little tricky... - therefore you find a set of redundant tanks. Cut out an oval and first of all



roll the cut out over the edge of the ruler along the long axis. Then cut along the four white lines. After applying glue to the grey triangles you fold them under the rectangular centre part grey triangles. This should form the tanks. You may trim the edges of the tanks, as shown on the right side in the picture above. Push the flaps of one of the side panels to the inside. Apply glue on the inside and mount the tank as shown. From the outside the tanks looks like below:



Now follow this procedure for all four tanks before you assemble the main body of the SVM. The white rectangular shapes on the SVM and PLM body are thermal *radiators*, which have a mirror-like surface. You may want to cut aluminium foil in the same size and shape and glue them on all white surfaces of the SVM to give the model a more authentic look.





The four elements (S) are *hold-downs* for the *solar arrays*. Cut them out and fold along the white line to have the same texture on both sides of the *hold-down*. They will be mounted on the upper edge of the SVM structure - two on each side - left and right of the *Solar Array*.

The main body of the SVM looks like this:

The top shows a cardboard cut-out that has the footprint of the *PLM*. A thin thread can be glued under this cardboard to suspend the finished model in the end.



The element (B) will become the inner cylinder of the SVM. Cut the element out and fold the little dark flaps to the backside and glue them. Roll the rectangle to a cylinder that fits into the round cut-out of the SVM. Glue the cylinder into the SVM. See the photo below, which shows the cylinder glued on the black underside of the SVM. The cylinder protrudes about a centimetre from the SVM, forming the *Separation Ring*.

To prepare the Solar Panel assembly first pierce the red circles on both sides of the SVM; first with a needle, then with the toothpick and finally widen the hole with the barbecue stick. On page 5 and 6 you find the solar panel front (V) and backsides (W). Cut out two pieces of card the size and shape of the *Solar Panels*. Cut slots to take the barbecue stick. Check the correct assembly: Only one long stick is used. It has to go through the spacecraft's SVM body, it has to cover the distance of the short grey arms and, finally, enter the card of the *Solar Panel* on each side. Mark the sticks accordingly. Verify with the tips of the stick the size of the openings in the spacecraft body and enlarge them if necessary, so that the barbecue stick will fit through it with only little resistance. Do not force the stick, turn it instead.



The blunt end of the barbecue stick is used in the first panel assembly. Glue the black back panels onto the card, glue the barbecue stick into the slot and cover with the front panel like a sandwich. At that stage your first Solar Array sandwich mounted with the long barbecue stick should look like in the picture above. When the glue of

this assembly set, use the point of the stick to pierce carefully through the spacecraft body. Repeat the sandwiching procedure for the second *Solar Panel*. This is when you will realise that you need an extra pair of hands to hold the body, glue the elements together and hold them in place until they harden...

Get help!

Finally the cylinder of the SVM is covered with a white *MLI*. Find the element (Q) on page 3 and cut it to the size that fits into the cylinder. Therefore the edges of the circle are to be cut and bent inwards. Apply plenty of glue and place the circle into the cylinder.

Back to the *PLM*. On sheet 3 cut out the *Spectrometer (SPI)* structure, that looks like a telescope tube. In order to get the correct diameter use a stack of 20 Eurocent coins. Roll the paper around the paper around the stack of coins and glue it together. The black flaps on one side of the tube are to be cut and folded into the inside of the telescope.



The top of the *spectrometer* is the mask, element (M), which can be glued slightly below the upper edge. The grey flaps on the other end fold to the inside of the tube and will be used to fix the *SPI* to the base of the *PLM*. Mount the *spectrometer* subassembly between on the ground-plate of the *PLM*.

On page 2 in the centre you find the outline view of the *SPI* from the front. Coloured and numbered boxes correspond to cut-outs on the same page. With the exception of the odd shaped box (1), all the others are relative straightforward rectangular boxes. Note that the grey sides are those that have to be glued to the telescope. The location of each box is indicated in the outline view. If in doubt, correlate also with the 3D drawing on page 7 or with the photos of the finished paper model. The regular boxes can all be assembled following the same principle. Fold the four elements so that a frame is created; with bottom and top to be folded and closing the box. However, box (1) is more complicated and cut-outs and folding are to be done carefully. This box, a main body with left and right smaller and lower bodies, is mounted both to the ground-plate of the *PLM* and against the telescope. Also the box (4) has no floor plate, but instead the two small sides are shaped to fit the round cylinder of the *spectrometer*.

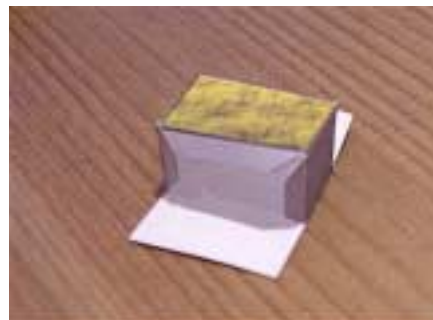



The cut-outs (O) and (N) on page 2 are parts of the *Star Tracker (STR)*. From the cut-out (O) fold an unsymmetrical box that becomes the housing for the tube. Roll the rectangular cut-out (N) tightly over a barbecue stick. Glue the roll together and mount housing and tube together in a way that the seam of the tube lines up with the grey underside of the housing. This way it will not be visible after integration to the PLM. There are two nearly identical STR units, only the length of the silver-grey top varies. When both are glued and hardened, put the *PLM* on the side and mount the *STRs*, as shown in the picture below.

The same construction principle applies to the *Optical Monitoring Camera (OMC)* to be mounted on the other side of the *PLM*. Housing and tube are the two first cut-outs under (K), while the third is a shade to protect the *OMC's* detector from direct sunlight. The backside of the baffle is to be painted black. It will become the inner part of the baffle assembly. Cut along the triangle side panels over the length of the grey flaps. When you have prepared the folds, the piece with the black dot will become the base. Fold the grey flaps and the triangular sidewalls downwards.



The folding between the rectangular and the dotted square makes the 3D shape of the shade. The black dot will be mounted on the tubes end. The grey end of the tube vanishes this time in the housing. Again, pay attention to orientation of the seam of the tube, so it is hidden in the final assembly on the *PLM*.

There are a few remaining boxes to be build and placed. On the side of the *PLM* body the long box of cut-out (L) is to be fitted between the struts. Note that these boxes do not have a ground plate. The open design gives you a little more flexibility to glue the box neatly into place. The grey side faces the *PLM* sidewall, while the flaps face the ground plate. For a more original look you might want to put aluminium foil on the white surface of the box, which act as *radiators*.

This improvement of your model can actually be applied to all whitish surfaces on the *PLM* and the *SVM*.

There are two final boxes to be mounted, numbered (8) on page 2. They fit next to the *SPI*, but on the outside of the forward struts. Again refer to page 9 or the models photograph for the proper positioning.

Finally you have to mate the *SVM* and the *PLM*. If you want to suspend the model from a ceiling, you put a long thread between the two surfaces, which are to be covered with glue. If the thread leaves the sandwich on the side opposite to the *SPI*, you have the more impressive view of the spacecraft pointing downwards.

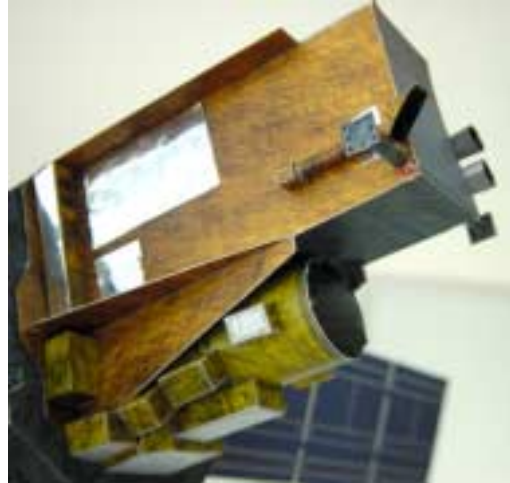

Well, you've made it. If your model looks like the pictures on the next page, all you need is add propellant: it's time to pure yourself a nice glass of vodka, celebrate your integration skills, contemplate about the Russian launcher that put the spacecraft into orbit in 2002 and about the mysteries the Integral spacecraft is about to resolve.

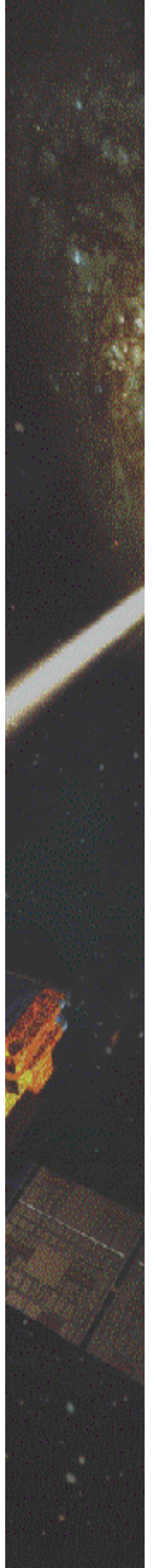

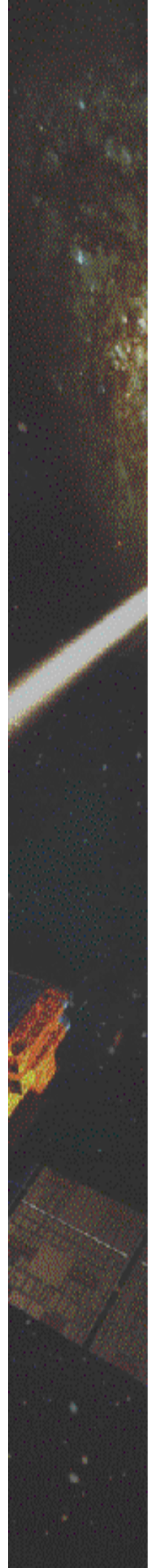
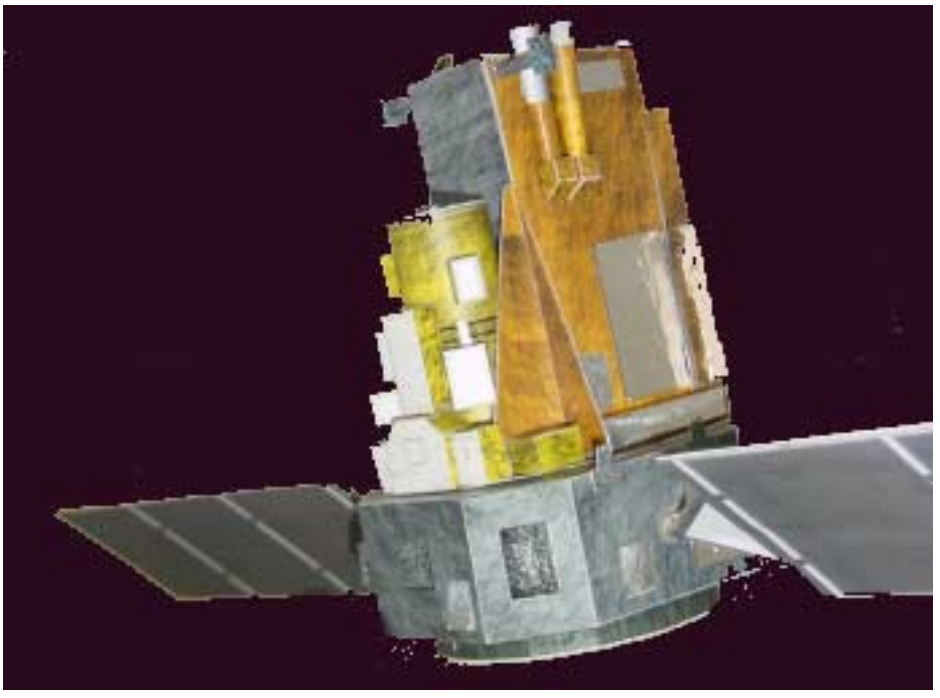
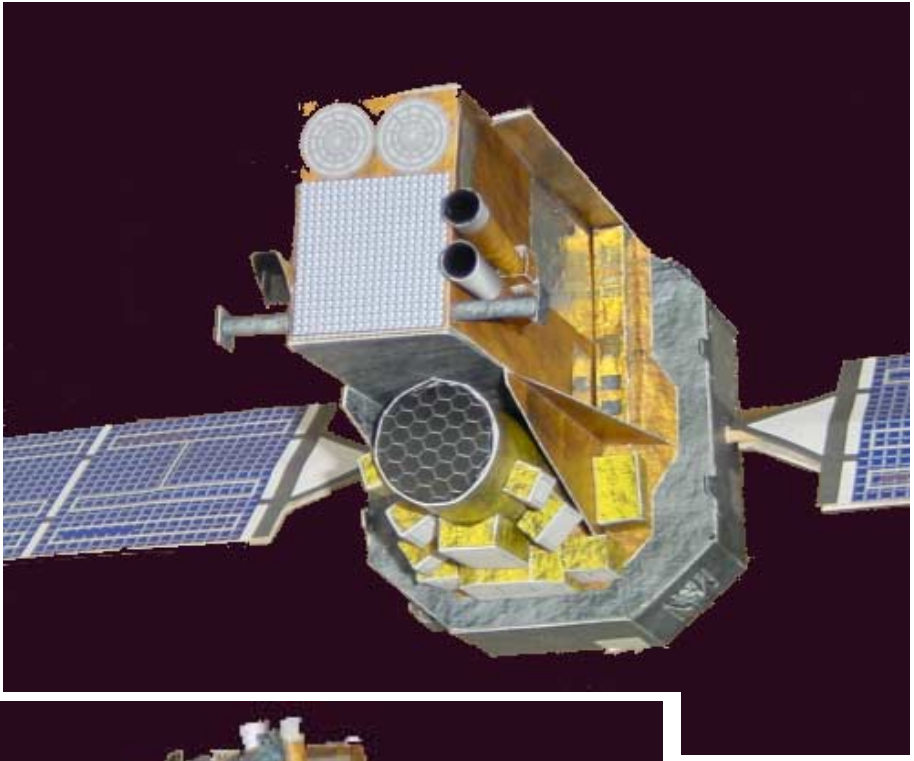
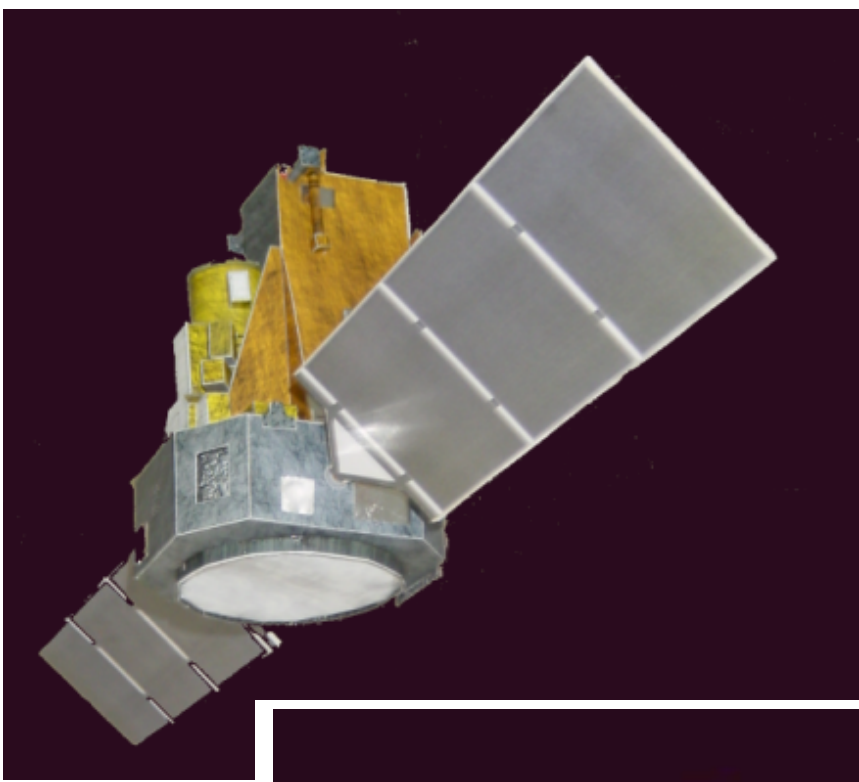

Appendix :

Introduction to the Integral Science

Gamma-ray astronomy is more complicated than other branches of astronomy because at high energies matter is transparent, and therefore source detection and imaging cannot be accomplished with standard optical-like technologies. In addition, the weakness of the source fluxes calls for instruments with large detector areas, which tend to make them large and heavy.

Gamma-rays represent one of the most energetic forms of radiation in nature. They carry large quantities of energy radiated from some of the cataclysmic of all astronomical events, including exploding stars, colliding neutron stars, particles trapped in magnetic fields, and matter being swallowed by black holes. Integral's payload instruments – IBIS, OMC, JEM-X and SPI – study these gamma-rays through detailed imaging and high resolution spectroscopy, providing scientists around the world with their clearest views yet to the most extreme environments in our universe.

from: "The Integral Payload", G.Sarri, P.Garre, C.Schamberg & R.Carli
ESA Bulletin 111, August 2002

The Glossary

Coolers	Contrary to our experience on Earth where air or water transports heat from one place to the other to achieve an even distribution of temperature, conditions in space are more extreme. Due to the lack of any medium that could convey heat in open space, temperatures depend on whether a part of the spacecraft is illuminated by the sun (and gets quite hot) or is cast in shadow (and thus condemned to freeze). Since the spacecraft, its units and scientific instruments are limited to certain temperature ranges they can operate in, the temperature of the spacecraft has to be managed actively. This is done with the help of electric heaters and coolers. Note on the model that the coolers are all perpendicular oriented to the <i>Solar Arrays</i> or can be shadowed by the spacecraft body itself. This way they can radiate heat generated by units or instruments of the spacecraft most efficiently to open space.
IBIS	The Imager on-Board the Integral Satellite (IBIS) provides high resolution images of celestial objects of all classes, ranging from the most compact galactic systems to extra-galactic objects
JEM-X	The Joint European X-Ray Monitor (JEM-X) complements the observations of SPI and IBIS in the lower x-ray energy band. With its low angular resolution in that energy band it adds to the comprehensive understanding of physical phenomena in the celestial sources observed by the other Integral instruments.

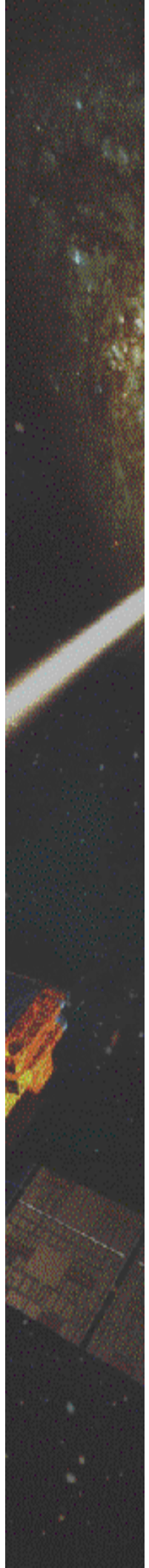

MLI	Stands for Multi Layer Isolation, a special foil that is used as a thermal insulation material in which spacecrafts are wrapped to protect them from the harsh thermal environment in space.
Hold-down	Small devices, that keep deployable elements into a stowed position during launch, until small explosive charges release the hold-downs and deploy antennas, solar arrays e.t.c.
Optical Monitoring Camera	The Optical Monitoring Camera (OMC) takes images on a large format CCD. These images provide data for calculating the pointing of the spacecrafts observatory instruments with an accuracy of a few arcseconds. Thus the OMC tells the observer exactly where in the sky the spectrometer or the IBIS is pointed.
OMC	See Optical Monitoring Camera
Payload Module	See PLM
PLM	The payload module (PLM) is the part of a spacecraft, a separate module dedicated to host the payload. In the case of scientific spacecrafts the PLM hosts the science instruments and experiments.
Radiator	A radiator can be understood as a passive <i>cooler</i> , a surface radiates heat from the spacecraft into space.
SAS	See Sun Acquisition Sensor
Separation Ring	The separation ring is connecting element between a spacecraft with the launcher, in other words, where they separate from each other. It is a very important and thus highly reliable manufactured mechanism.
Service Module	See SVM
Solar Array	The task of the Solar Arrays are to convert the energy of the sun light to electric energy for operating the spacecraft. The Solar Arrays feed the batteries with power to operate the spacecraft. With the <i>Solar Array Drive Mechanism</i> the Array can be turned and oriented to catch a maximum of sunlight available at any given orientation. However there are operation phases when the spacecraft flies through the shadow of Mars (eclipse) and the Solar Arrays are not illuminated. During these periods the operation of the spacecraft is done on battery power.
Spectrometer	The Spectrometer on Integral (SPI) performs high resolution spectrography. The instrument observes the most energetic phenomena in the universe, such as neutron stars, black holes, supernovae and thus will resolve some fundamental problems in physics and astronomy.
SPI	See Spectrometer
Solar Array Drive Mechanism	The <i>Solar Array Drive Mechanism</i> is an electrical motor at the foot of each Solar Array that can orientate the Array to catch a maximum of sunlight available at any given orientation
Star Tracker	The Star Tracker operates as the primary compass of a spacecraft. It compares the image of stars in its field of view with an internal map of the sky. As a result the spacecraft navigation system receives information on the orientation and attitude of the spacecraft in space. For this critical function two Star Trackers, looking at different parts of the sky, are commonly used for redundancy reasons.
STR	See Star Tracker



Sun Acquisition Sensor

The Sun Acquisition Sensor (sometimes abbreviated to Sun Sensor) is similar to the Star Tracker a device to determine the orientation of the spacecraft. However the Sun Sensor is cruder and thus more robust. It will only find a major light source, such as the sun, but also the reflecting light of a closeby planetary body (Earth, Moon, Mars). Sun Sensors play an important role in spacecraft emergency cases. If for instance for unknown reasons the normal operation pattern is interrupted and the spacecraft does not report back to ground as it routinely should, the spacecraft on board computer will declare an emergency. The spacecraft shuts down all but the essential systems and is put into a slow spin. During the spin the Sun Sensor is looking for the Sun, and as a first measure orientates the Solar Arrays towards the Sun to charge the batteries. One by one other manouvers are called up, such the Star Tracker operation and the Antenna being pointed towards Earth. Then the spacecraft will transmit its status and awaits assessment and new instructions from the Ground Control Operators at the European Space Agency's Operation Centre (ESOC).

SVM

The service module (SVM) is the part of a spacecraft that as a module is dedicated to host all utilities and services required to operate the payload in the specified orbit. Such services are the power management, the achievement and maintenance of the orbit, the communication management, but also the thermal and mechanical integrity.

